



HITACHI

SERVICE MANUAL

TK**No. 1526E**

D-E10

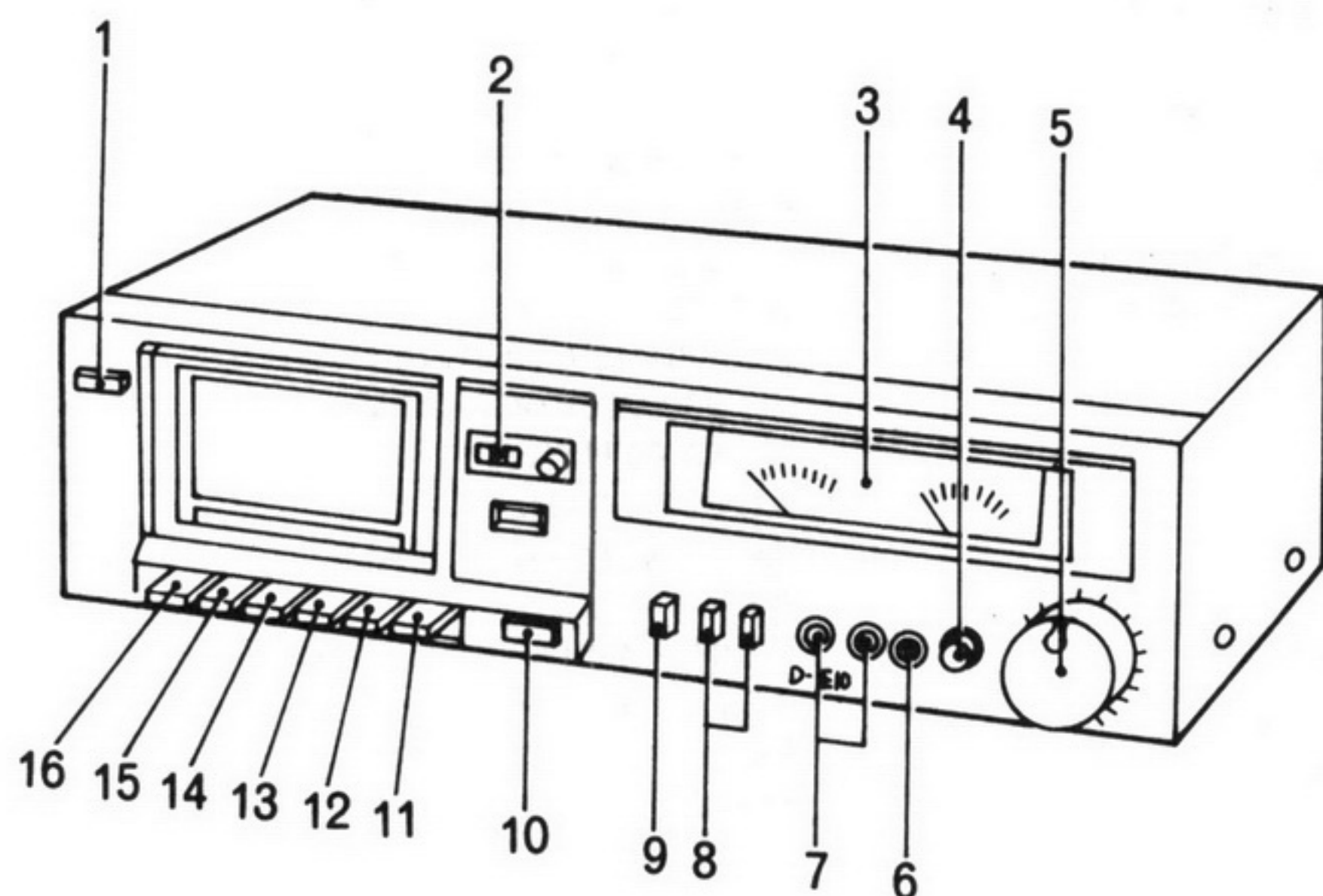
(U, C, FS, BS, AU, W)

CONTENTS

Specifications.....	2
Disassembly.....	2
Adjustment	3
Inspection of mechanism.....	4
Lubrication.....	4
Schematic diagram.....	5
Circuit board diagram.....	7
Exploded view (Cassette Chassis).....	10
Exploded view (Cabinet).....	11
Replacement parts list.....	12

KEY TO ILLUSTRATIONS

- | | |
|------------------------------|-------------------------|
| 1. Power (Mains) switch | 9. Dolby NR switch |
| 2. Tape counter | 10. Eject button |
| 3. VU meters | 11. Pause button |
| 4. Recording balance control | 12. Stop button |
| 5. Recording level control | 13. Fast forward button |
| 6. Headphone socket | 14. Playback button |
| 7. Microphone sockets | 15. Rewind button |
| 8. Tape select switches | 16. Record button |

SAFETY PRECAUTION

The following precautions should be observed when servicing.

1. Since many parts in the unit have special safety related characteristics, always use genuine Hitachi's replacement parts. Especially critical parts in the power circuit block should not be replaced with other makes. Critical parts are marked with Δ in the schematic diagram and circuit board diagram.
2. Before returning a repaired unit to the customer, the service technician must thoroughly test the unit to ascertain that it is completely safe to operate without danger of electrical shock.

SPECIFICATIONS AND PARTS ARE SUBJECT TO CHANGE FOR IMPROVEMENT

STEREO CASSETTE TAPE DECK

March 1981**TOKAI WORKS**

SPECIFICATIONS

Semi-conductors :		Wow and Flutter :	0.07% (WRMS) 0.20%*
ICs :	3	Input Sensitivity and Impedance :	
Transistors :	10 (U, C, BS) 11 (FS, AU, W)	Microphone :	0.3mV, 300 ohms ~ 5k ohms
Diodes :	7 (U, C, BS) 10 (FS, AU, W)	Line in :	60mV, 47k ohms or more
LED :	1	DIN (Record/Playback) :	0.3mV, 3k ohms (FS, AU, W)
Track System :	4 track 2 channel stereo	Output Level :	400mV or more
Tape :	Cassette tape (C-30, 60, 90)	Output Load Impedance :	
Tape Speed :	4.75cm/s	Line out :	50k ohms or more
Recording System and Bias Frequency :	AC bias, 85 kHz	DIN (Record/Playback) :	50k ohms or more (FS, AU, W)
Erasing System :	AC erase	Headphone :	8 ohms ~ 2k ohms
Erase Ratio :	65 dB or more (at 1 kHz)	Distortion :	1.2% (1 kHz, 0VU)
Frequency Response :		Crosstalk :	60 dB or more (at 1 kHz)
ER/UD (NOR) :	20 Hz ~ 15 kHz 30 Hz ~ 14 kHz (± 3 dB) 30 Hz ~ 14 kHz *	Channel Separation :	30 dB or more (at 1 kHz)
EX/SX (CrO ₂) :	20 Hz ~ 16 kHz 30 Hz ~ 15 kHz (± 3 dB) 30 Hz ~ 15 kHz *	Power Supply :	AC 120V, 60 Hz (U, C) AC 100-110V/115-127V/ 200-220V/230-250V, 50/60 Hz (W) AC 220V, 50 Hz (FS) AC 240V, 50 Hz (BS, AU)
ME (Metal) :	20 Hz ~ 17 kHz 30 Hz ~ 16 kHz (± 3 dB) 30 Hz ~ 16 kHz *	Power Consumption :	9W
S/N (Signal to Noise Ratio) :		Dimensions :	110(H) \times 435(W) \times 203(D)mm
Dolby NR OFF :	57 dB (Weighted A, Reference 3% THD Metal Tape) 57 dB*	Weight :	3.2kg
Dolby NR ON :	64 dB (Weighted A, Reference 3% THD Metal Tape) 64 dB*	Motor :	Electronically controlled DC motor
		Heads :	Metal SL Record/playback head Three-gap ferrite Erase head

* According to DIN 45 500

DISASSEMBLY

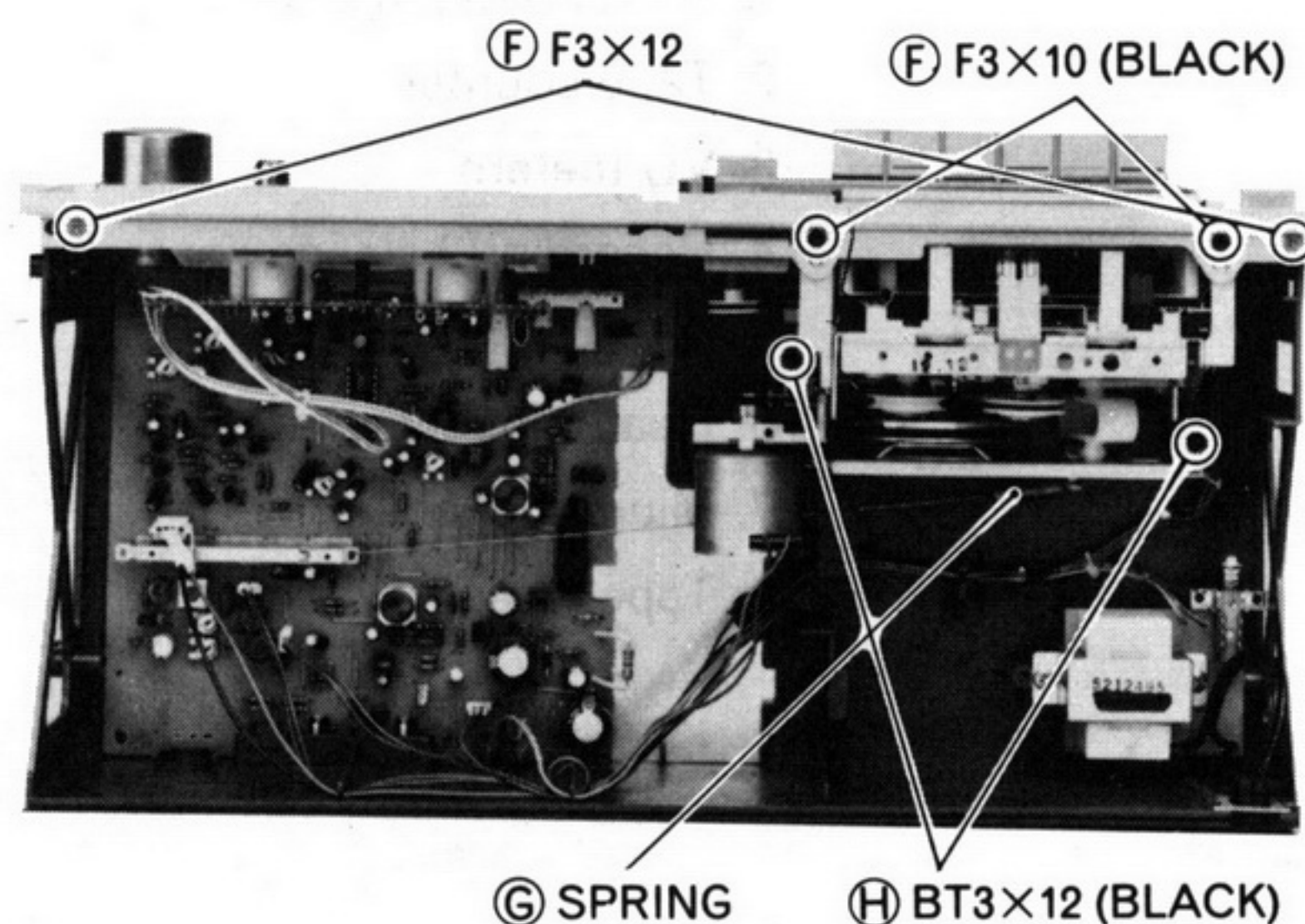
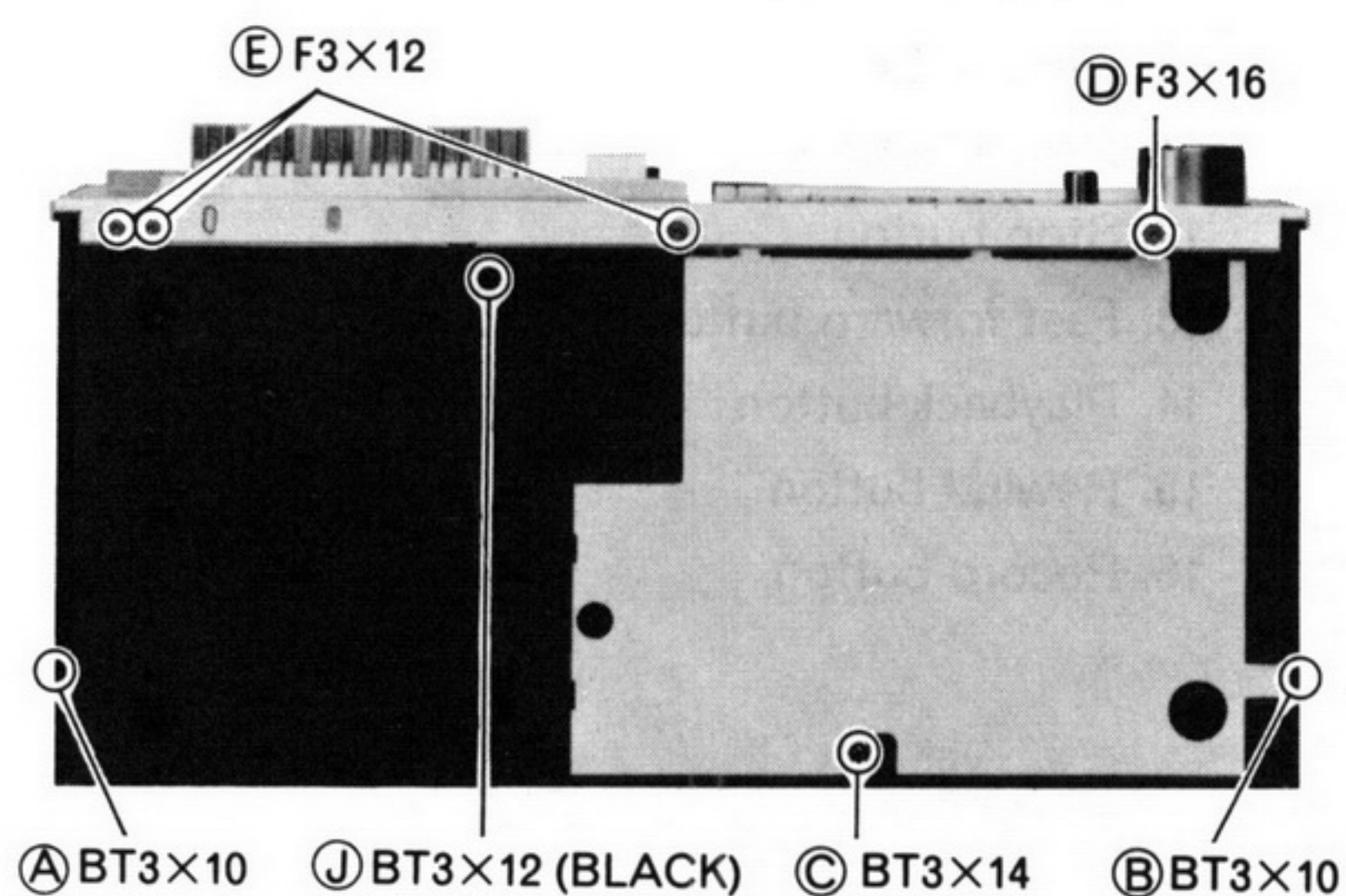

1. Cassette door

Depress the eject button to open the cassette holder.
Lift up the cassette door to remove it.

2. Upper cover

Remove (A) and (B) (two) screws.

3. Bottom cover

Remove (B), (C) and (D) (three) screws.

4. Front panel

1) Remove two knobs (REC level, REC balance).
2) Remove (D), (E) and (F) (eight) screws.

5. Cassette chassis

1) Remove (G) spring.
2) Remove (H) and (J) (three) screws.

IC2 L,R
NE646B
DOLBY NR

Q3L,R
2SC2320
MUTING

ZD1
RD5.1E
LEVEL SHIFT

DIL,R
IK34A
RECT FOR METER

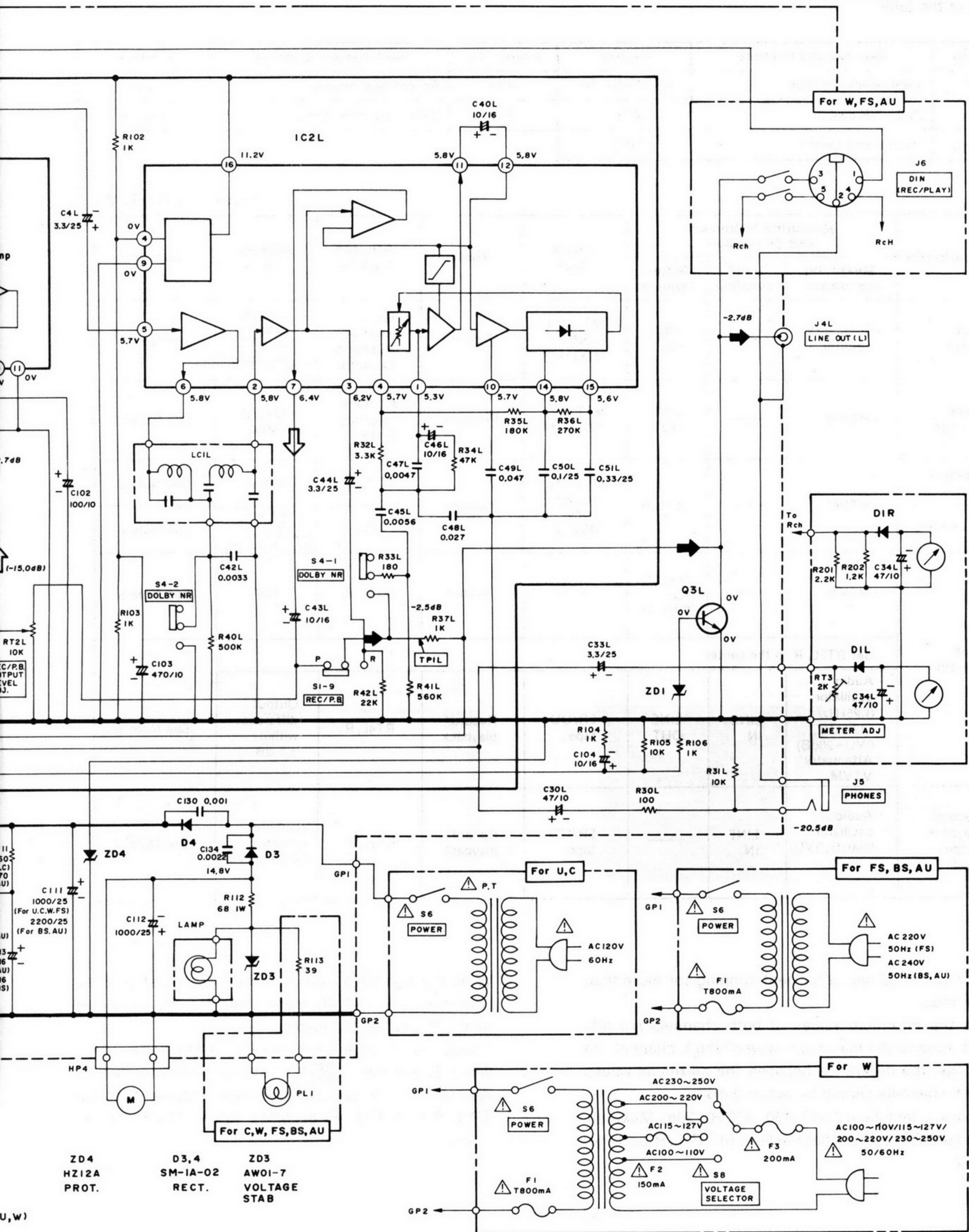

ZD4
HZ12A
PROT.

D3,4
SM-1A-02
RECT.

ZD3
AW01-7
VOLTAGE
STAB